

VU-17 Flat Panel LCD Monitor

The VU-17 is a high resolution LCD flat panel monitor, with a large viewing area in a thin, lightweight package. It's 1280 x 1024 resolution provides a perfect match for any Dage-MTI camera, and is well suited to a wide variety of applications. Take a look at the Dage VU Series monitors today.



FEATURES

- 17" 4:3 LCD Monitor
- Brightness 300cd/m²
- Contrast 1000:1
- Rack Mount Available
- Inputs Composite, S-Video, YPbPr , VGA, DVI
- 3D Comb Filter
- Dynamic Noise Reduction

SPECIFICATIONS

System	PAL, NTSC	
VGA	Display Panel	LCD
	Resolution	1280 X 1024
	Brightness	300cd/m
	Contrast	1000:1
	Response Time	8ms
	Viewing Angle	170°/160°
Video Input/Output	Composite Video Input	2 channel BNC input 1.0v p-p, 75Ω, 2 channel output
	S-Video	1 channel input (Y/C), 1 channel looping input
	YPbPr	1 channel input
	DVI	1 channel input
	VGA	1 channel input
Audio	3 channel input, 2W, 3 channel output	
Menu	OSD	
Dimension	386 X 338 X70 (mm)	
Weight	5.0kg	
Power Source	Voltage	AC 100~230V 50~60Hz
	Power	Max 32W
Operating Environment	Operating Temperature: 0° C~40° C: Operating Humidity: 10% ~ 85%	

VU-17 FLAT PANEL LCD MONITOR

FRONT PANEL CONTROLS

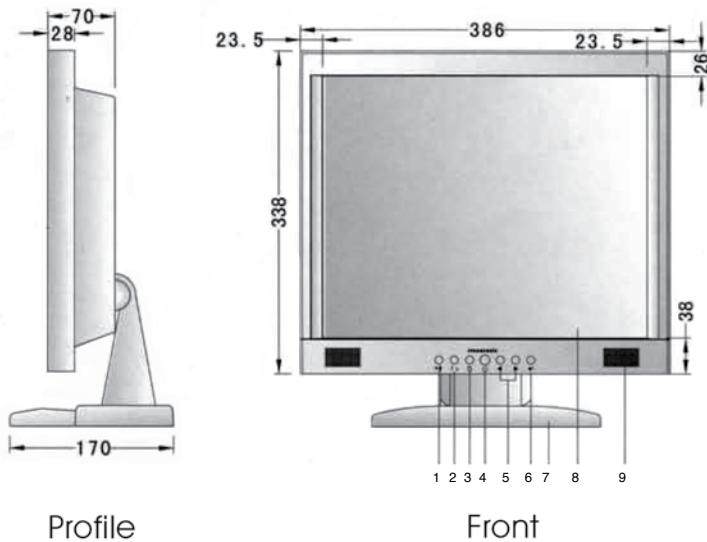

1. Remote IR
2. Input select: AV1, AV2, S-Video, YPbPr, PC, and DVI
3. OSD On/Off
4. Power
5. a. OSD off: adjust volume (range 1-100)
b. OSD on: select forward/backward
c. Change current value or function of item selected
6. Select current item
7. Monitor bracket
8. Display panel
9. Speakers

REAR PANEL CONTROLS

10. RGB/YUV: YPbPr IN
(This monitor has YUV functionality. RGB not available.)
11. VIDEO1: VIDEO IN/OUT
12. VIDEO 2: VIDEO 2 IN/OUT
13. SVHS: S-Video IN/OUT
14. AUDIO1: VIDEO 1, S-VIDEO AUDIO IN/OUT
15. AUDIO2: VIDEO2, YPbPr AUDIO IN/OUT
16. AUDIO3: VGA, DVI AUDIO IN/OUT
17. VGA: VGA IN
18. DVI: DVI IN
19. Power Switch

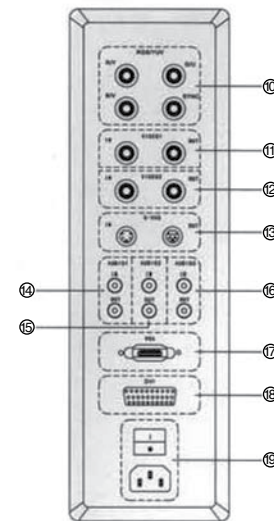

Dage-MTI (219) 872-5514

Call for additional product information or free product demos.

Visit online at www.dagemti.com.